

1998. Ant diversity patterns along an elevational gradient in the Réserve Spéciale d'Anjanaharibe-Sud and on the western Masoala Peninsula, Madagascar. *Fieldiana Zoology* (n.s.) 90:39-67.

Ant Diversity Patterns Along an Elevational Gradient in the Réserve Spéciale d'Anjanaharibe-Sud and on the Western Masoala Peninsula, Madagascar

Brian L. Fisher¹

Abstract

Leaf litter ant faunas were inventoried in Madagascar at 875, 1200, 1280, 1565, and 1985 m in the Réserve Spéciale (RS) d'Anjanaharibe-Sud and at 25, 425, and 825 m on the western Masoala Peninsula. Within each elevational zone, survey methods involved a combination of pitfall and leaf litter sampling along a 250 m transect. From pitfall and leaf litter samples, I collected and identified 24,586 ants belonging to 180 species and 25 genera in the RS d'Anjanaharibe-Sud; general collecting yielded an additional 35 species. On the Masoala Peninsula, pitfall and leaf litter collections yielded 52,307 ants comprising 167 species and 25 genera; general collecting added 30 more species. For the RS d'Anjanaharibe-Sud and the Masoala Peninsula combined, a total of 325 species and 34 genera were collected.

For each elevation, two different species richness estimators, incidence-based coverage estimator and first-order jackknife, gave comparable results. Species accumulation curves approached an asymptote and demonstrated the efficacy of these inventory techniques. Species collected and their relative abundances are presented. Species richness peaked at midelevation. Species turnover and faunal similarity measures demonstrated a division in ant communities between lowland forest ≤ 875 m and montane forest ≥ 1200 m. A midelevation peak in species richness is argued to be the result of the mixing of two distinct, lower and montane forest ant assemblages.

Résumé

L'entomofaune des fourmis de la litière du sol de la Réserve Spéciale d'Anjanaharibe-Sud a été inventoriée à 875, 1200, 1280, 1565, et 1985 m d'altitude ainsi qu'à 25, 425, et 825 m d'altitude dans la partie occidentale la péninsule de Masoala. Au niveau de chaque station altitudinale échantillonnée, les méthodes d'inventaire utilisées ont compris une combinaison de pièges "pitfall" et d'échantillonnages de la litière du sol le long d'un transect de 250 m de long. Les pièges "pitfall" et les échantillons de la litière du sol ont permis la collecte et l'identification de 24.586 fourmis appartenant à 180 espèces et 25 genres provenant de la RS d'Anjanaharibe-Sud. Les collectes aléatoires ont permis la collecte de 35 autres espèces. Dans la péninsule de Masoala, les pièges "pitfall" et les échantillons de la litière du sol ont permis la collecte et l'identification de 52.307 fourmis appartenant à 167 espèces et 25 genres différents. Les collectes aléatoires au niveau de ce site ont permis la collecte de 30 espèces supplé-

¹ Department of Entomology, University of California, Davis, CA 95616-8584 U.S.A. Current address: Life Sciences Division, South African Museum, P.O. Box 61, 8000 Cape Town, South Africa.

mentaires. Le total combiné de la RS d'Anjanaharibe-Sud et de la péninsule de Masoala se monte à 325 espèces et 34 genres.

Pour chaque station d'altitude, deux modes d'estimation, "incidence-based coverage estimator (ICE)" et "first-order jackknife", ont donné des résultats comparables. Les courbes d'accumulation spécifique atteignent une asymptote et démontrent par cela l'efficacité de ces techniques d'inventaire. Les espèces collectées et leur abondance relative sont présentées. La richesse spécifique présente un pic à moyenne altitude. Le taux de renouvellement spécifique et les indices de similarité montrent qu'il existe un changement dans la communauté de fourmis entre la forêt de basse altitude, 875 m et la forêt d'altitude à partir de 1200 m. Le pic de richesse spécifique constaté à moyenne altitude est considéré comme étant le résultat de la conjugaison de la richesse des forêts des communautés rencontrées à basse altitude et en altitude.

Introduction

Although invertebrates and plants make up the vast majority of species in forest habitats, landscape-level patterns of invertebrate biodiversity are little known for tropical ecosystems (Gaston et al., 1993). Such distributional data will largely determine how effective conservation areas are at representing distinct assemblages of species. Species richness, the number of species in a given area, is the currency of biodiversity, but for most groups, we lack knowledge of how to inventory species (Palmer, 1995).

Effective inventory methods must be rapid and repeatable and must contain sufficient subsamples for statistical analysis of species richness and abundance or coverage. Major impediments to developing survey methods and interpreting their results include (1) the effects of scale on species distributions and species turnover; (2) sampling biases due to particular survey methods, habitat differences among sites, and seasonality; (3) problems with completeness of sampling for hyperdiverse groups such as insects; and (4) logistical constraints.

I attempted to address these needs by developing and testing effective sampling and estimation procedures for a hyperdiverse group of terrestrial insects, ants, along elevational gradients in the Réserve Spéciale (RS) d'Anjanaharibe-Sud and on the western Masoala Peninsula, Madagascar. Similar methods were used to inventory ants in the Réserve Naturelle Intégrale (RNI) d'Andringitra (Fisher, 1996a). Specifically, this study tested methods to survey leaf litter ants and evaluated the effect of elevation on species richness. In addition, I compared measures of faunal similarity and species turnover (beta diversity) for

ant species across elevations sampled from 25 m to 1985 m.

Methods

Study Sites

In addition to the survey sites in the RS d'Anjanaharibe-Sud (Chapter 1), surveys were conducted between 13 November and 11 December 1993 on the western side of the Masoala Peninsula in the province of Toamasina. The Masoala Peninsula collection sites were located (1) 6.3 km south of Ambanizana, Andranobe Field Station, 15°41'S, 49°57'E, 1–100 m; (2) 5.3 km south-southeast of Ambanizana, Andranobe Field Station, 15°40'S, 49°58'E, 350–500 m; (3) 6.2 km south-southeast of Ambanizana, Andranobe Field Station, Be Dinta Camp, 15°40'S, 50°00'E, 600 m; and (4) 6.9 km northeast of Ambanizana, Ambohitsitondroina Mountain, 15°34'S, 50°00'E, 800–1080 m. The Ambohitsitondroina Mountains reach a height of 1080 m and are part of the same ridge formation that includes the Andranobe Field Station, which rises to an elevation of 600 m at Be Dinta Camp.

Survey Methods

In the RS d'Anjanaharibe-Sud, intensive ant surveys were conducted at four sites located at 875, 1200, 1565, and 1985 m. An additional partial survey was conducted at 1280 m. On the Masoala Peninsula, intensive surveys were conducted at three sites located at 25, 425, and 825 m. At each elevation the survey method used 50 pitfalls

and 50 leaf litter samples, in parallel lines 10 m apart, along a 250 m transect. The site for each transect was chosen with the intent of sampling representative microhabitats found at each elevation (Palmer, 1995). Pitfall traps were placed and leaf litter samples gathered every 5 m along the transect. Pitfall traps consisted of test tubes (18 mm internal diameter \times 150 mm long and partly filled to an approximate depth of 50 mm with soapy water and a 5% ethylene glycol solution), inserted into polyvinyl chloride sleeves and buried with the rim flush with the soil surface. Traps were left in place for 4 days.

I extracted invertebrates from samples of leaf litter (leaf mold and rotten wood) using a modified form of the Winkler extractor (Fig. 4-1) (Besuchet et al., 1987; Fisher, 1996a). The leaf litter samples involved establishing 50 1-m² plots separated by 5 m along the transect line. The leaf litter inside each 1-m² plot was collected and sifted through a wire sieve of 1 cm grid size. Before sifting, the leaf litter material was minced using a machete to disturb ant nests in small twigs and decayed logs. Approximately 2 liters of sifted litter were taken from each 1 m² plot. At low elevations (<800 m), where litter may be sparse, less than 2 liters was sometimes taken. In montane areas, where the litter is often thick, 2 liters was the maximum amount taken at each subsample site. The sifted litter samples were taken back to a tarp-covered laboratory constructed at each camp, and ants were extracted from the sifted litter during a 48-hour period in modified Winkler sacks (Fig. 4-1, "mini-Winkler"). The standard Winkler sack holds up to four 2-liter samples of sifted litter, whereas mini-Winklers are designed to hold only one 2-liter sample. Each sifted litter sample was held in a 0.4 mm grid size mesh sack that was vertically suspended in a larger cotton enclosure. Ants and other invertebrates that worked their way out of drying litter contained in the mesh sack fell through the cloth enclosure into a 0.53-liter plastic bag (Whirl-Pak, Nasco, Fort Atkinson, Wisc.) containing 70% ethanol at the bottom of the mini-Winkler. Because insects are less effectively extracted from wet leaf litter, sifting was done at least 24 h after significant rainfall.

I also surveyed ants through general collecting, defined as any collection that was separate from the mini-Winkler or pitfall transects, including searching in rotten logs and stumps, in dead and live branches, in bamboo, on low vegetation, under canopy moss and epiphytes, under stones, and leaf litter sifting. At each transect site, general

collections were conducted for approximately a 2-day period. General collections were made within 1 km and within 75 m in elevation of each transect. These collections included samples of the arboreal ants found on low vegetation that were not sampled by pitfalls or mini-Winklers. Ants sampled with general collection methods, therefore, were not used in the analysis of the efficacy of the survey of the leaf litter ants, faunal similarity, or beta diversity.

At 1280 m in the RS d'Anjanaharibe-Sud, a partial transect of 50 pitfalls and only 26 mini-Winklers was completed. This site was located in a ravine and was characterized by a thick clay soil with a high moisture content. A partial survey was conducted at 1280 m to compare with the 1200 m site, which contained habitats more typical of the elevational zone.

Identification

Specimens were identified to morphospecies level on the basis of characters previously established to be important at the species level for each genus. When possible, species names were attached to these morphospecies by using taxonomic descriptions (see Fisher, 1997, for a list of references) and by comparing specimens with those previously collected by Ward and Fisher in Madagascar that had been compared with type material. Species codes used in this chapter correspond to species codes used in Fisher (1996a). A representative set of specimens will be deposited at the Museum of Comparative Zoology, Harvard University, and in Madagascar.

Data Analysis

EVALUATION OF SAMPLING METHOD—To assess the completeness of the survey for the elevations sampled, I plotted cumulative species per sample curves for each elevation. Species accumulation was plotted as a function of the number of leaf litter and pitfall trap samples taken. For the analysis each leaf litter sample was paired with the adjacent pitfall sample, collectively termed a station sample. For 1280 m in the RS d'Anjanaharibe-Sud, only the first 26 pitfalls were combined with the 26 litter samples. Species accumulation curves for the 50 (26 for 1280 m) stations per transect, as well as incidence-based coverage estimator (ICE) and first-order jackknife estimates of the to-

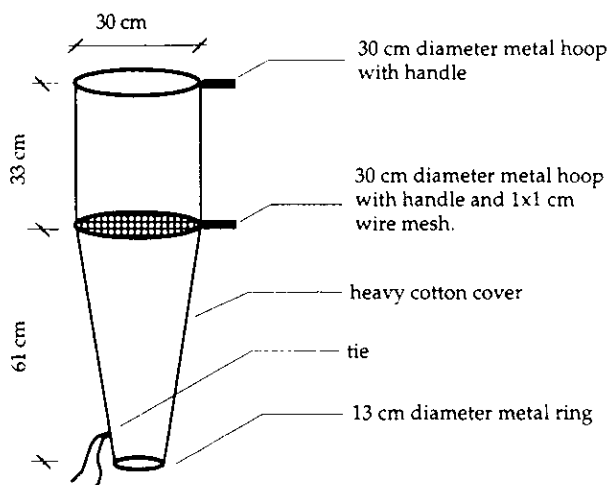

(a) Litter sifter

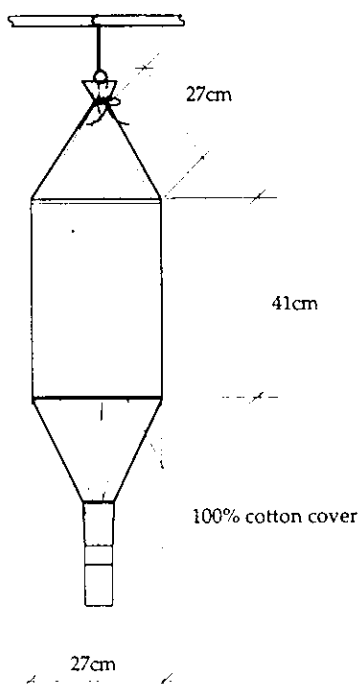

(b) Front view with fabric cover

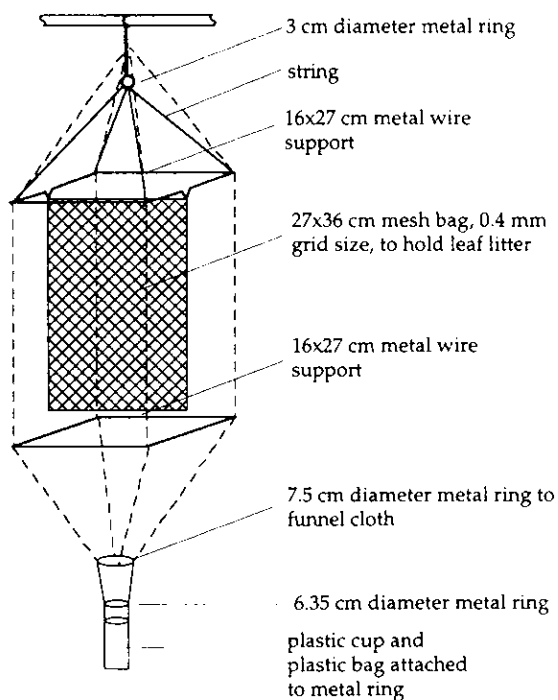

(c) 3-Dimensional view without fabric cover

FIG. 4-1. Litter sifter (a) and mini-Winkler sack design. (b) Front view with fabric cover and (c) three-dimensional view without fabric cover. Litter is first sifted through a 1 cm grid size wire mesh. The sifted litter is placed in the 0.4 mm grid size mesh sack, which is hung vertically in the mini-Winkler enclosure. Ants and other invertebrates leave the litter in the mesh sack and are collected in a plastic bag containing ethanol at the base of the mini-Winkler. The plastic bag is attached to a plastic cup with its bottom removed. At each camp, 25 mini-Winklers are set up under a tarp and hung on wooden poles. Cotton string is looped around the base of each mini-Winkler to stabilize it during windy conditions.

tal number of species in the local community from which the samples were taken, are plotted for each succeeding station sample. The ICE and the first-order jackknife methods are nonparametric approaches to improving the estimate of species richness. The ICE method is based on species found in 10 or fewer sampling units (Lee & Chao, 1994; Chazdon et al., in press). Standard deviations of ICE estimates are based on bootstrap estimates (R. K. Colwell, unpubl.). The first-order jackknife method is based on the observed frequency of unique species (the jackknife estimator and its SD are defined in Heltshe & Forrester, 1983). For species accumulation curves, sample order was randomized 100 times, and the means and SDs of the ICE and jackknife estimates were computed for each succeeding station using the program Estimates (R. K. Colwell, unpubl.; see also Colwell & Coddington, 1994; Chazdon et al., in press). If the species accumulation or jackknife estimate curves approach an asymptote, then the transect length is arguably sufficient. Conversely, if the curves do not begin to flatten out, more intensive sampling may be necessary to accurately compare diversities between elevations. This assumes that for hyperdiverse groups, more intensive sampling (i.e., larger numbers of subsamples) will eventually generate curves that approach, not necessarily reach, an asymptote. With a high number of rare species, these curves may never completely flatten out and reach an asymptote but may continue to slowly increase with more sampling. That is, the entire area may need to be exhaustively surveyed to collect every species.

ANT DIVERSITY—Data on both species richness and abundance were used to assess the change in species composition along the elevational gradient. Only records of ant workers were used in these calculations. Because alates may travel considerable distances during dispersal, their presence does not necessarily signify the establishment of a colony of that species within the transect zone. In addition, collections of queens and males dispersing from nearby nests at the time of the survey may not reflect the relative abundance of the species. Because ants are colonial, abundance measures were based not on the total number of individual workers collected at each transect site but on species frequency (proportion of stations, out of 50, in which each species was collected at a site).

For each elevation, I compared ICE and first-order jackknife estimates of total species richness and 95% confidence limits. Overlap and species

turnover (i.e., "complementarity," *sensu* Colwell & Coddington, 1994) of the ant assemblages at different elevations were assessed using faunal similarity and beta diversity indices. Similarity of the ant fauna was assessed using two different measures: (1) the Jaccard Index, which is based on presence and absence data only: $C_j = j/(a + b - j)$, where j = number of species found at both elevations, a = number of species at elevation A, and b = number of species at elevation B (Magurran, 1988); and (2) the simplified Morisita Index, which incorporates abundance data:

$$C_{MI} = \frac{2\sum(an \times bn)}{(da + db)aN \times bN}$$

where

$$da = \frac{\sum an_i^2}{aN^2}$$

and

$$db = \frac{\sum bn_i^2}{bN^2}$$

where aN = total number of station or species occurrences at elevation A, bN = total number of station or species occurrences at elevation B, an_i = the number of stations occupied by the i th species at elevation A, and bn_i = the number of stations occupied by the i th species at elevation B (Horn, 1966; Wolda, 1981). Similarity indices based on presence/absence data, such as the Jaccard, have been shown to be strongly influenced by species richness and sample size (Wolda, 1981). The Morisita Index is nearly independent of species richness and sample size (Wolda, 1981) and therefore may be more appropriate for comparisons of ant assemblages along an elevational gradient.

Beta diversity (species turnover between elevations) was calculated in two ways. First, the beta diversity measure of Whittaker (1960) was used: $\beta-1 = (S/a) - 1$, where S = the total number of species in the two elevations combined and a = the mean number of species in each elevation. Because this measure does not distinguish between species turnover and the loss of species along a gradient without adding new species, the measure of beta diversity developed by Harrison et al. (1992) was also calculated: $\beta-2 = (S/a_{max}) - 1$, where S = the same as $\beta-1$ above and a_{max} = the maximum value of alpha diversity (i.e., number of species) among the elevations compared.

The number of species unique to an elevation and the number of species shared between elevations were also compared. These comparisons incorporated elevational sites from both localities but excluded the partial transect at 1280 m. The number of species unique to 875 was calculated in the absence of the 825 m site. Likewise, 875 m site data were not used in calculating species unique to the 825 m site.

Results

In the RS d'Anjanaharibe-Sud, I collected and identified 28,248 ants representing 215 species and 30 genera from general collections and the leaf litter and pitfall methods. These included 553 queens and 211 males. The leaf litter and pitfall methods yielded 24,586 worker ants belonging to 180 species. On the Masoala Peninsula, I collected and identified 54,263 ants representing 197 species and 31 genera from general collections and the leaf litter and pitfall methods. These included 474 queens and 22 males. The leaf litter and pitfall methods produced 52,307 ants representing 167 species and 25 genera. For the RS d'Anjanaharibe-Sud and the Masoala Peninsula combined, a total of 325 species and 33 genera were collected from all methods. From the pitfall and leaf litter methods, a total of 271 species were collected, with 76 species shared between localities. Lists of ant species in the RS d'Anjanaharibe-Sud (Table 4-1) and the Masoala Peninsula (Table 4-2), based on all collecting techniques and separated by elevation and technique, are presented. For the Masoala Peninsula, general collections at 600 m and from 950 to 1080 m are also presented (Table 4-2). Absent from Table 4-1 are records of species from the RS d'Anjanaharibe-Sud known from queens only (*Serrastruma ludovici* from 875 m and *Camponotus* sp. 31 from 1985 m).

Within the RS d'Anjanaharibe-Sud, the 875 m zone had the greatest total number of species recorded (125 species total from all methods; 97 species total from litter and pitfall samples; Table 4-1). If the data for 1200 and 1280 m are combined, the number of species is similar to that from 875 m (117 species total from all methods; 100 species total from litter and pitfall samples). On the Masoala Peninsula, the total number of species was greatest at 825 m (112 species total

from all methods; 109 species total from litter and pitfall samples).

The number of species and number of individuals collected from pitfall traps were low compared to those collected by the mini-Winkler method, except for 1280 m in the RS d'Anjanaharibe-Sud, where two pitfall traps collected an exceptional number (a total of 1,183 individuals) of *Paratrechina* sp. 5. Only 10 species were collected by pitfall traps that were not also collected by the mini-Winkler method. Five of the 10 were *Leptogenys* species, which are large, fast-moving terrestrial (epigaeic) species with solitary foragers. In dry forest in southwestern Madagascar, however, pitfall traps collected a greater number of individuals and species (Fisher & Razafimandimby, 1997).

The abundance of ant species is presented in Table 4-3 for the RS d'Anjanaharibe-Sud and in Table 4-4 for the Masoala Peninsula. Both the proportion of stations at which each species was collected and the number of individuals collected are given. General collections are not included. In the RS d'Anjanaharibe-Sud, only one species of 180, *Paratrechina* sp. 5, was found at all elevations. The relative frequency of occurrence of *Paratrechina* sp. 5, however, differed considerably from one site to the next (0.06 and 0.02 at 875 m and 1985 m, respectively, and 0.46, 0.42, and 0.54 at 1200, 1280, and 1565 m, respectively; Table 4-3). Excluding the partial transect at 1280 m, only 10 species were found at three of the four elevational sites. On the Masoala Peninsula, 30 species out of 167 (18%) were found at all three elevations sampled.

The number of ant species and abundance, measured as the total number of stations at which each species was collected, peaked at the mid-elevations and quickly decreased at high elevations (Fig. 4-2). The 825 m (Masoala Peninsula) site was the highest in species richness, and the 425 m site (Masoala Peninsula) had the highest abundance. There is also a significant relationship between the total number of individuals and the total number of stations at which each species was collected at a site (Tables 4-1, 4-2; for all elevations with complete transects, $r^2 = .66$, $p = 0.027$).

The relative prevalence of each subfamily for the combined pitfall and leaf litter samples is shown in Table 4-5. The fauna was dominated by Myrmicinae in both number of species and number of individuals, followed by the Ponerinae. Between localities, the taxonomic ratio of Ponerinae

TABLE 4-1. Ant species list for the RS d'Anjanaharibe-Sud, including elevation and collection method.*

Genus	Species	875 m	1200 m	1280 m	1565 m	1985 m	
CERAPACHYINAE							
<i>Cerapachys</i>	1	G	W, G				
	5	W	W				
	7	W, G					
	10	G					
	11	G					
	12	W					
	14	W	W				
	15	W					
	16	W					
	17		W	W			
	18		W	W, P			
	19					P	
	20					W, G	
	21				W		
	22			G			
	<i>Simopone</i>	3	G				
		4	G				
		5		G			
	DOLICHODERINAE						
	<i>Technomyrmex</i>	4		P			
	FORMICINAE						
	CAMPONOTINI						
<i>Camponotus</i>	5		W, P	W, G			
	6	G					
	16	W, G	W, P, G	W	W		
	17		G		W, G		
	19	P, G	G				
	20		G				
	21	G	W		W		
	23		G		G		
	24	W, G					
	26	G					
	27		G				
	28		W, G		W		
	32		W				
	33		W				
	35	G	W, G				
	37	G		G			
	38		G				
	39					W, P, G	
	40	W, G					
	<i>hildebrandti</i>	W, G					
<i>nasica</i>		G	G				
<i>putatus</i>	G						
LASHINI							
<i>Paratrechina</i>	1	W, G	W, P, G		W		
	5	W, G	W, P, G	W, P, G	W, P, G	P	
	6	W, G	W, G	W	W, G		
	11	W	W				
PLAGIOLEPIDINI							
<i>Plagiolepis</i>	2	G					
MYRMICINAE							
CATAULACINI							
<i>Cataulacus</i>	3	G	W, G		W		
	1	G					
	<i>oberthueri</i>	G					
	<i>regularis</i>	G					

TABLE 4-1. *Continued.*

Genus	Species	875 m	1200 m	1280 m	1565 m	1985 m
CREMATOGASTRINI						
<i>Crematogaster</i>	3	W, G				
	5	W, P, G	W, P, G		W, G	
	7	W	G			
	10		W, P, G	W	W, G	
DACETONINI						
<i>Kyidris</i>	1	W, G	W			
	4		G			
<i>Smithistruma</i>	5				W, G	
	1		G, W	W		
<i>Strumigenys</i>	13	W	W			
	19	W, G				
	22	W	W			
	24	W	W			
	25		W, P			W
	26	W				
	31					W
	32					W
	33		W	W		
	34	W				
	35	W, P				
	36	W				
	38		W, G			
	39	W	W	W, G	W	
	40			W	W	
	41				W	
	42				W	W
43				W		
44					W	
51	W					
52	W	W, G				
54		W	W	W, G		
56				W, G		
MYRMICINI						
<i>Eutetramorium</i>	<i>mocquersyi</i>	P, G				
PHEIDOLINI						
<i>Pheidole</i>	8	P	W, P	W		
	13	G	W, G			
	23				W	
	30				W, P, G	W, P, G
	36				W, P, G	
	37	W	W, P	W, P	W, P, G	
	38		G	W, P	W, P, G	
	39				G	
	40				W	
	41	W, G	W, P, G	W, P		
	42	W, G	W, P, G			
	43	W, P, G				
	44	W, G	W, P	W		
	45			W, P		
	46			W		
	47		W, P	W, P, G		
	48		W, P			
49		W, P, G				
50	W	W				
51	W	W, P				
52		W, G				
53		W, P				

TABLE 4-1. Continued.

Genus	Species	875 m	1200 m	1280 m	1565 m	1985 m
	54	W, P				
	55	W, G				
	56	W, G				
	57	W, P				
	58	W, P				
	68		W			
	71	W				
	<i>veteratrix</i>	W, P, G	W, P	W, P		
PHEIDOLOGETONINI						
<i>Oligomyrmex</i>	3	W, G	W			
	6	W	W	W, P		
PODOMYRMINI						
<i>Terataner</i>	1	G				
SOLENOPSISIDINI						
<i>Monomorium</i>	1		W	W	W	
	4				W, G	
	7		W			
	14	W				
	16	W	W			
	20					W, G
	26	W				
	27				W, G	W
	31		W			
	35	W				
	37	W, G				
	38	W	W	W		
	39	W	W	W	W	
	40		W			
TETRAMORIINI						
<i>Tetramorium</i>	6	W, G	W, G			
	14		W, P, G	W, P	W, P, G	
	19	G				
	23	W, P, G	W			
	25	G	W			
	28				G	
	29	G	W, G	W, G		
	37	W, P	W, P	W, P	W	
	38	G	G		G	
	39		G			
	40	W, P, G	W	W, G	W	
	44					W
	45			W		
	46		W			
	47			W		
	48			W		
	49		W			
	50	W, P, G		W	W, P	
	51	W				
	52				P	
	<i>andrei</i>	W, P, G	W, G		W, P, G	
	<i>dysalium</i>	W				
	<i>naganum</i>	W, P	W, P	W, P, G		
	<i>schaufusii</i>		W, G	W	W	
	<i>tosii</i>	W, G				
INCERTAE SEDIS						
Undescribed genus	4		W, P	W	W, G	
	5				W, P, G	W, P, G

TABLE 4-1. *Continued.*

Genus	Species	875 m	1200 m	1280 m	1565 m	1985 m
PONERINAE						
AMBLYOPONINI						
<i>Amblyopone</i>	5	W		W		
<i>Mystrum</i>	1	W				
	3	P				
	5	W				
<i>Prionopelta</i>	1	W, G	W			
	3	W, G				
	4	W	W	W		
	6		G			
ECTATOMMINI						
<i>Discothyrea</i>	1		W	W	W	
	4	W	W			
	5	W				
<i>Proceratium</i>	4	W				
	5	W				
	6		W	W	W	
PONERINI						
<i>Anochetus</i>	<i>grandidieri</i>	W	W			
<i>Hypoponera</i>	1		W	W	W	
	6			W		
	9	W				
	11		W, G	W	W	
	19				W, G	
	20					W, P
	21		W	W	W	
	22				W, G	
	23		W		W	
	24				W, G	
	25		W, G	W, G		
	26		W	W		
	28		W	W		
	29		W			
	30		W			
	31	W				
	32	W				
	34	W				
	35	W				
	36	W				
	37	W				
	38	W				
	39	W				
	40	W				
	41	W, G				
	42	W				
	47	W				
	<i>sakalava</i>	W, G	W, G	W, G	G	
<i>Leptogenys</i>	5	P				
	9	W, G				
	10	G				
	11	G			P	
	14			P		
<i>Odontomachus</i>	<i>coquereli</i>	W, G				
<i>Pachycondyla</i>	1	W, G	W			
	3		W			
	<i>cambouei</i>	W, P, G	W	W, P		
	<i>perroti</i>	G				
	<i>sikorae</i>		G			

TABLE 4-1. *Continued.*

Genus	Species	875 m	1200 m	1280 m	1565 m	1985 m
PSEUDOMYRMECINAE						
<i>Tetraponera</i>	cf. <i>grandidieri</i>	G				
	psw-70	G				
	psw-92	G	G			
Total species: G		65	43	12	25	4
Total species: P		20	22	14	12	5
Total species: W		92	85	52	47	8
Total species: W and P		97	86	53	50	9
Total species: All methods		125	103	55	55	9
Number (%) of unique species: All methods		70 (56%)	25 (24%)	10 (18%)	17 (31%)	4 (44%)
Number (%) of unique species: W and P		55 (57%)	20 (23%)	9 (17%)	17 (34%)	4 (44%)
Total number of G collections		85	55	11	36	18
Number of workers: G		1,151	663	87	733	264
Number of workers: P		175	440	1,741	293	48
Number of workers: W		6,661	6,033	1,393	6,130	1,672
Total number of workers		7,960	7,136	3,221	7,156	1,984
Abundance		941	759	256	442	151

* Only collections of workers are presented (G = general collections; P = pitfall transect samples; W = mini-Winkler leaf litter transect samples). A total of 213 ant species and 27,484 workers were collected. In addition, *Serrastruma ludovici* (875 m) and *Camponotus* sp. 31 (1985 m) were recorded from queens only. Abundance refers to the total number of stations at which each species was collected.

to Myrmicinae was similar: 0.51 in the RS d'Anjanaharibe-Sud and 0.45 on the Masoala Peninsula. The taxonomic ratio, however, differed between elevations, peaking at midelevation (Table 4-5).

Observed number of species, ICE and first-order jackknife estimates of species richness, their SDs, and their 95% confidence intervals are presented for the RS d'Anjanaharibe-Sud and the Masoala Peninsula (Table 4-6). Species accumulation curves for observed number of species and ICE and jackknife estimates approached an asymptote but were still increasing slowly (Fig. 4-3, the RS d'Anjanaharibe-Sud; Fig. 4-4, the Masoala Peninsula). This indicates that within the area of the survey, the technique used collected the majority of ants foraging and living in the leaf litter in the area encompassed by the 250 m transect and that with increased sampling effort using the same methods (i.e., adding more pitfall and litter stations) in the same area, only marginal increases in species richness should be attained. In a combined analysis of the elevations in the RS d'Anjanaharibe-Sud (Fig. 4-3f) and on the western Masoala Peninsula (Fig. 4-4d), the pitfall and mini-Winkler methods collected 84% and 86%, respectively, of the total number of leaf litter ant species estimated by the first-order jackknife method to occur in each region.

Faunal similarity values based on presence/ab-

sence data (Jaccard Index) and abundance (simplified Morisita Index) are presented for the RS d'Anjanaharibe-Sud and the Masoala Peninsula (Table 4-7). The Morisita Index, which relies on abundance data, is less affected by strong differences in species richness between elevations than the Jaccard Index. In the RS d'Anjanaharibe-Sud, Jaccard similarity values were lowest between 1985 m, which contained only nine species, and the three other elevations (875, 1200, and 1565 m). The lowest Morisita values were between 875 and 1565 m, between 875 and 1985 m, and between 1200 and 1985 m. Jaccard values were similar between the 875 and 1200 m sites (0.230) and the 1200 and 1565 m sites (0.236). The Morisita similarity value for the 875–1200 m sites (0.272) was greater than that for the 1200–1565 m sites (0.198). On the Masoala Peninsula, the lowest similarity was between 25 and 825 m. The lowest similarity between adjacent elevations was between 425 and 825 m. The 875 m site in the RS d'Anjanaharibe-Sud was more similar to the 825 m site on the Masoala Peninsula than it was to the 1200 m in the RS d'Anjanaharibe-Sud. Likewise, the 825 m site was more similar to the 875 m site than it was to the 425 m site on the Masoala Peninsula (Table 4-7). The overall Jaccard Index value of similarity between all elevations in the two localities was 0.278.

Beta diversity values showed related trends in

TABLE 4-2. Ant species list for the western Masoala Peninsula, including elevation and collection method.*

Genus	Species	25 m	425 m	600 m	825 m	950-1080 m
CERAPACHYINAE						
<i>Cerapachys</i>	1			G	W, G	G
	5				W	
	7		W		W, G	
	13				W	
	14				W, G	
	16				W	
	22	W, G	W, G		W	
DOLICHODERINAE						
<i>Tapinoma</i>	1	G				
<i>Technomyrmex</i>	1			G		
	3		W		W	
	<i>albipes</i>	G				
FORMICINAE						
CAMPONOTINI						
<i>Camponotus</i>	2				W, G	
	5	G	W, G		W, G	
	12				W, G	
	15				W	
	16	W, G	W	G	W, P	
	18			G		G
	19			G		G
	22					G
	24		W, G	G	W, G	G
	25	G				
	28		W, G			G
	29					G
	30		W, P, G		W, P	
	32					G
	34	G	G			G
	35	W, G	W	G	W	G
36			G			
	<i>macquerysi</i>	G				
	<i>putatus</i>		W			
LASINI						
<i>Paratrechina</i>	1	W, P				
	5	W, P	W, P		W, P, G	
	6	W	W, G		W, G	G
	8		W, P	G	W, P, G	G
	9	G	W			
	10	W, P				
PLAGIOLEPIDINI						
<i>Plagiolepis</i>	3	W	W		W	G
MYRMICINAE						
CATAULACINI						
<i>Cataulacus</i>	1	G		G		
	<i>oberthueri</i>			G		
CREMATOGASTRINI						
<i>Crematogaster</i>	3	W	W		W	
	7				G	
	8	W	W			
	9	W, G	W, G			
	12				W	
	<i>schenki</i>				W	

TABLE 4-2. *Continued.*

Genus	Species	25 m	425 m	600 m	825 m	950-1080 m
DACETONINI						
<i>Kvidris</i>	1	W	W, G		W, G	
<i>Smithistruma</i>	6	W	W		W	
	7	W	W, G			
<i>Strumigenys</i>	1		W		W	
	13	W	W		W	
	14	W	W, G		W	
	19		W		W	
	22	W	W		W	
	23				W	
	24	W	W			
	25	W	W		W	
	26	W	W		W	
	27	W	W, G			
	28	W	W		W	
	29		W		W	
	30				W	
	37		W			
	51				W, G	
	52				W	
	53	W	W, G			
	55				W	
FORMICOXENINI						
<i>Leptothorax</i>	3					G
PHEIDOLINI						
<i>Aphaenogaster</i>	<i>gonacantha</i>		W, P, G	G		
<i>Pheidole</i>	8					G
	13				W	
	20	W, P	W, P			
	23	W				
	41				W	
	43	W, P, G	W, P			
	44	W, P	W, P		W, P	
	49				W, P	
	50	W	W, P		W	
	52				W	
	53	W, P, G	W		W, P	
	54				W	
	55				G	
	58	G	W		W, P	
	60	G				
	61			G		
	62				W	
	63				W, P, G	
	64				W	
	65				W	
	66				W	
	67				W	
	68	W, P	W, P, G			
	69	W, P	W, P			
	70	W, P	W			
	71	W, P	W			
	72		W, G			
	73	W, P	W, P			
	74	W				
	<i>oswaldi</i>	W, P, G	W, P, G			
	<i>spinosa</i>	W, P, G	W, P			
	<i>veteratrix</i>				W, P, G	G

TABLE 4-2. *Continued.*

Genus	Species	25 m	425 m	600 m	825 m	950-1080 m
PHEIDOLOGETONINI						
<i>Oligomyrmex</i>	3	W, P, G			W	
	6	W	W, P		W	
PODOMYRMINI						
<i>Terataner</i>	<i>alluaudi</i>	G				
SOLENOPSISINI						
<i>Monomorium</i>	2				W	
	5		W		W	
	7		W		W, G	
	14	W, P	W			
	23		W, P, G		W, P, G	
	24				W, P, G	
	26	W	W			
	28				W	
	32					G
	33				W	
	34				W, P, G	
	36	W	W		W	
	38				W	
	39	W	W		W	
41		W				
42	W			G	W	
TETRAMORIINI						
<i>Tetramorium</i>	6	G	W		W, G	
	7	W			W	
	16	W	W, P, G			
	21	W, G	W, P, G			
	23	W, P, G	W, P		G	
	24				W, P, G	
	25		P, G		W	
	26		P			
	29				W	G
	34	W	W, P			
	35	W				
	36		W, P, G			
	37		W, G		W, P, G	
	39				W	
	40	W	W, G		W, G	
	41	W	W, P, G			
	42		W			
	43	W	W			
	<i>andrei</i>	W, P, G	W, P		P	
	<i>bicarinatum</i>	G				
	<i>dysalum</i>	W, P, G	P, G		W	
<i>electrum</i>				W		
<i>marginatum</i>		W, P, G		W		
<i>naganum</i>	W, P	W		W, P, G		
<i>tosii</i>	W, G	W, P, G				
INCERTAE SEDIS						
Undescribed genus	2				W, G	
	3	W	W, G			
PONERINAE						
AMBLYOPONINI						
<i>Amblyopone</i>	1		W			
	4				W	
<i>Mystrium</i>	3				W	
	4	W, P, G	W, P, G			
	5		W			

TABLE 4-2. *Continued.*

Genus	Species	25 m	425 m	600 m	825 m	950-1080 m
<i>Prionopelta</i>	1	W	W, P, G		W, G	
	4				W, G	G
	5	W	W, G			
ECTATOMMINI						
<i>Discothyrea</i>	3				W, G	
	5		W		W, G	
	6	W				
	7		W			
<i>Proceratium</i>	2	W, P, G	W			
	<i>diplopyx</i>				W	
PLATYTHYREINI						
<i>Platythyrea</i>	<i>bicuspis</i>			G		
PONERINI						
<i>Anochetus</i>	<i>grandidieri</i>	W, P	W, G		W, G	
<i>Hypoponeura</i>	22				W	
	26		W		W, G	
	29				W	
	32	W, P	W			
	33	W, P	W			
	36	W, P, G	W, P			
	38				W	
	39				W	
	43	W, G	W, P			
	44	W	W			
	45	G				
	46	W	W		W	G
	47		W		W	
	48				W	
	49				W	
	50				W, G	
	51		W			
52	W					
<i>Leptogenys</i>	<i>sakalava</i>	W, G	W	G	W, G	
	4		W			
	5				W	
	6				P	
	7				P	
8	G					
11				W		
<i>Odontomachus</i>	<i>coquereli</i>		W, G		W, G	G
<i>Pachycondyla</i>	1				W	
	2	W, P	W, P, G			
	<i>cambouei</i>	W, P	W, P, G		W, P	
<i>Ponera</i>	<i>perroti</i>	W, P, G		G		
	1	W	W, G			
PSEUDOMYRMECINAE						
<i>Tetraponera</i>	<i>grandidieri</i>	G		G		G
	<i>longula</i>	G				
Total species: G		37	37	18	36	22
Total species: P		29	33		20	
Total species: W		76	98		106	
Total species: W and P		76	101		109	
Total species: All methods		93	102		112	
Number (%) unique species: All methods		17 (18%)	11 (11%)	5 (28%)	53 (47%)	6 (27%)
Number (%) of unique species: W and P		8 (11%)	15 (15%)		55 (50%)	
Total number of G collections		48	22	22	25	33
Number of workers: G		367	325	150	403	215
Number of workers: P		884	569		1,661	
Number of workers: W		14,980	21,827		12,386	

TABLE 4-2. *Continued.*

Genus	Species	25 m	425 m	600 m	825 m	950-1080 m
Total number of workers		16,231	22,721		14,450	
Abundance		905	1,087		1,007	

* Only collections of workers are presented (G = general collections; P = pitfall transect samples; W = mini-Winkler leaf litter transect samples). A total of 213 ant species and 27,484 workers were collected. Abundance refers to the total number of stations at which each species was collected.

[†] Samples from 150 m.

levels of species turnover between adjacent elevations with greatest species turnover at midelevations (Table 4-8). In the RS d'Anjanaharibe-Sud, the 1985 m site had a high beta-1 value in comparison to other elevations because of the few numbers of species present (compare to beta-2). Because of the loss of species with elevation, beta-2 is the preferred measure of species turnover. Excluding 1280 m, the highest beta-2 value was between the 875 and 1200 m sites. On the Masoala Peninsula, the highest value of beta-2 was between 425 and 825 m. In comparison between the two localities, species turnover was similar along the elevational gradient. In the RS d'Anjanaharibe-Sud, the 875-1565 m beta-2 value was 0.392, and on the Masoala Peninsula, the 25-825 m beta-2 value was a similar 0.394. The overall beta-2 values of species turnover between all elevations at both localities were also similar, 0.568 and 0.511, respectively (Table 4-8).

The 825 and 875 m sites had the greatest number of species unique to an elevation (Table 4-9). The 1985 m site, however, had the highest percentage of species unique to an elevation (Table 4-9). The midelevation sites shared the highest number of species with other sites when compared to the 25 m and higher elevation (≥ 1200 m) sites. The 25 and 425 m sites had many species in common, but the 425, 825, and 875 m sites shared more species with higher elevations.

Discussion

Elevational Gradient and Complementarity

Species richness did not decrease monotonically as a function of elevation. When the data from the RS d'Anjanaharibe-Sud and the Masoala Peninsula are combined, there is a peak in richness at 800-900 m (Fig. 4-2). A midelevation peak has been documented for a few taxa in the tropics (see

review in Rahbek, 1995), including ants in Panama (Olson, 1994). The generally accepted pattern, however, is that species richness declines with elevation (Rahbek, 1995), and this pattern is analogous to the latitudinal gradient (Stevens, 1992). The midelevation peak observed in ant species richness in Madagascar may be the result of a mixing of two distinct ant assemblages along an ecotone (see below).

After the midelevation peak, species richness declines rapidly, reaching a minimum of nine species at 1985 m (Fig. 4-2). Species richness was also found to decrease rapidly with increasing elevation above 800 m in the RNI d'Andringitra (Fisher, 1996a) and in Panama (Olson, 1994). This rapid decrease in species richness probably reflects climatic variables, mainly the reduction of radiant energy, which may affect larval development and worker foraging activities (Brown, 1973; Fisher, 1996a) and decrease primary productivity (Rosenzweig & Abramsky, 1993).

Faunal similarity and beta diversity measures (Tables 4-7 and 4-8) suggest a division of the ant fauna into two communities, one occurring in lowland forests at ≤ 875 m and the other in montane forests at ≥ 1200 m. Species turnover was greatest at midelevation. The same pattern was found in the RNI d'Andringitra (Fisher, 1996a), where the greatest turnover in ant species assemblages occurred between transects conducted at midelevation (785 and 825 m) and the 1275 m zone.

Analysis of the midelevation taxa is complicated by the separation of the lower elevation sites on the Masoala Peninsula from the higher sites in the RS d'Anjanaharibe-Sud. The high number of species unique to 825 and 875 m (Table 4-9) is a biased result. Both the 825 and 875 m sites were compared to higher and lower sites, respectively, in the other locality. For example, the 875 m site in the RS d'Anjanaharibe-Sud was compared with the 425 m site from the Masoala Peninsula. A certain proportion of the species unique to the 825

TABLE 4-3. Abundance, measured as the frequency of occurrence (proportion of stations out of 50 [26 for 1280 m] paired pitfall and leaf litter samples at which each species was recorded) for each elevation in the RS d'Anjanaharibe-Sud.*

Genus	Species	875 m	1200 m	1280 m	1565 m	1985 m
CERAPACHYINAE						
<i>Cerapachys</i>	1		0.06 (25)			
	5	0.10 (26)	0.02 (1)			
	7	0.02 (5)				
	12	0.04 (3)				
	14	0.02 (3)	0.04 (3)			
	15	0.02 (1)				
	16	0.04 (7)				
	17		0.06 (9)	0.02 (1)		
	18		0.06 (11)	0.02 (1)		
	19				0.02 (1)	
	20				0.10 (15)	
21			0.04 (2)			
DOLICHODERINAE						
<i>Technomyrmex</i>	4		0.02 (1)			
FORMICINAE						
CAMPONOTINI						
<i>Camponotus</i>	5		0.06 (5)	0.02 (1)		
	16	0.04 (2)	0.14 (23)	0.02 (5)	0.04 (2)	
	17				0.04 (19)	
	19	0.02 (1)				
	21		0.04 (11)		0.02 (1)	
	24	0.02 (1)				
	28		0.06 (11)		0.02 (6)	
	32		0.14 (33)			
	33		0.02 (1)			
	35		0.02 (3)			
	39					0.22 (56)
40	0.04 (19)					
<i>hildebrandti</i>	0.02 (2)					
LASINI						
<i>Paratrechina</i>	1	0.78 (673)	0.22 (44)		0.04 (21)	
	5	0.06 (50)	0.46 (1,765)	0.42 (527)	0.54 (3,972)	0.02 (1)
	6	0.50 (350)	0.06 (46)	0.04 (10)	0.08 (11)	
	11	0.04 (2)	0.06 (9)			
PLAGIOLEPIDINI						
<i>Plagiolepis</i>	3		0.80 (127)		0.02 (1)	
MYRMICINAE						
CREMATOGASTRINI						
<i>Crematogaster</i>	3	0.06 (15)				
	5	0.34 (22)	0.10 (5)		0.02 (2)	
	7	0.02 (1)				
	10		0.08 (4)	0.02 (1)	0.06 (3)	
DACETONINI						
<i>Kyidris</i>	1	0.32 (233)	0.10 (66)			
	5				0.16 (12)	
	1		0.54 (210)	0.14 (24)		
	13	0.04 (3)	0.02 (2)			
	19	0.04 (2)				
	22	0.34 (30)	0.08 (4)			
	24	0.54 (151)	0.02 (1)			
	25		0.34 (64)		0.02 (1)	
	26	0.42 (107)				
	31				0.04 (6)	
	32				0.02 (1)	

TABLE 4-3. *Continued.*

Genus	Species	875 m	1200 m	1280 m	1565 m	1985 m
	33		0.02 (1)	0.02 (1)		
	34	0.64 (154)				
	35	0.46 (119)				
	36	0.04 (2)				
	38		0.06 (3)			
	39	0.02 (2)	0.34 (28)	0.20 (16)	0.40 (39)	
	40			0.02 (3)	0.30 (22)	
	41				0.08 (7)	
	42				0.02 (1)	0.22 (21)
	43			0.02 (1)		
	44				0.02 (1)	
	51	0.02 (1)				
	52	0.04 (2)	0.24 (32)			
	54		0.18 (13)	0.02 (1)		
	56			0.06 (4)		
MYRMICINI						
<i>Eutetramorium</i>	<i>mocquerysi</i>	0.02 (1)				
PHEIDOLINI						
<i>Pheidole</i>	8	0.06 (8)	0.18 (25)	0.06 (31)		
	13		0.02 (1)			
	23				0.02 (1)	
	30				0.62 (374)	0.96 (1,166)
	36				0.46 (176)	
	37	0.06 (8)	0.08 (11)	0.20 (44)	0.66 (190)	
	38			0.02 (1)	0.34 (264)	
	40				0.02 (1)	
	41	0.02 (1)	0.86 (484)	0.08 (26)		
	42	0.02 (1)	0.20 (21)			
	43	0.44 (69)				
	44	0.52 (454)	0.06 (13)	0.02 (21)		
	45			0.26 (160)		
	46			0.06 (9)		
	47		0.08 (13)	0.08 (19)		
	48		0.64 (530)			
	49		0.26 (57)			
	50	0.40 (166)	0.06 (10)			
	51	0.02 (2)	0.14 (23)			
	52		0.04 (2)			
	53	0.24 (103)				
	54	0.06 (12)				
	55	0.02 (1)				
	56	0.26 (69)				
	57	0.16 (37)				
	58	0.08 (8)				
	68		0.02 (1)			
	71	0.02 (1)				
	<i>veteratrix</i>	0.84 (335)	0.20 (109)	0.06 (25)		
PHEIDOLOGETONINI						
<i>Oligomyrmex</i>	3	0.56 (303)	0.54 (163)			
	6	0.46 (203)	0.26 (49)	0.18 (21)		
SOLENOPSISINI						
<i>Monomorium</i>	1		0.04 (5)	0.04 (2)	0.24 (54)	
	4				0.20 (137)	
	7		0.06 (6)			
	14	0.06 (6)				
	16	0.04 (2)	0.24 (59)			
	20					0.10 (7)
	26	0.02 (1)				

TABLE 4-3. *Continued.*

Genus	Species	875 m	1200 m	1280 m	1565 m	1985 m
	27				0.16 (95)	0.02 (1)
	31		0.02 (4)			
	35	0.26 (69)				
	37	0.08 (41)				
	38	0.44 (88)	0.38 (86)	0.14 (12)		
	39	0.48 (308)	0.64 (666)	0.32 (166)	0.08 (22)	
	40		0.02 (2)			
TETRAMORIINI						
<i>Tetramorium</i>	6	0.26 (39)	0.20 (14)			
	14		0.60 (332)	0.04 (6)	0.42 (55)	
	23	0.44 (44)	0.10 (6)			
	25		0.08 (11)			
	29		0.08 (6)	0.04 (13)		
	37	0.04 (3)	0.26 (55)	0.12 (12)	0.06 (3)	
	40	0.84 (379)	0.22 (36)	0.12 (22)	0.08 (4)	
	44					0.04 (27)
	45			0.08 (4)		
	46		0.02 (1)			
	47			0.02 (1)		
	48			0.08 (12)		
	49		0.06 (14)			
	50	0.54 (88)		0.02 (5)	0.30 (24)	
	51	0.04 (15)				
	52				0.02 (1)	
	<i>andrei</i>	0.64 (226)	0.18 (71)		0.20 (163)	
	<i>dysalum</i>	0.02 (1)				
	<i>naganum</i>	0.12 (11)	0.20 (59)	0.46 (97)		
	<i>schaufusii</i>		0.12 (14)	0.06 (3)	0.24 (17)	
	<i>tosii</i>	0.14 (18)				
INCERTAE SEDIS						
Undescribed genus	4		0.06 (12)	0.06 (5)	0.38 (39)	
	5				0.32 (64)	0.68 (166)
PONERINAE						
AMBLYOPONINI						
<i>Amblyopone</i>	5	0.02 (3)		0.06 (3)		
<i>Mystrium</i>	1	0.20 (23)				
	3	0.02 (1)				
	5	0.04 (2)				
<i>Prionopelta</i>	1	0.42 (73)	0.12 (9)			
	3	0.80 (717)				
	4	0.06 (11)	0.24 (29)	0.10 (5)		
ECTATOMMINI						
<i>Discothyrea</i>	1		0.04 (3)	0.04 (2)	0.02 (1)	
	4	0.04 (3)	0.04 (2)			
	5	0.04 (2)				
<i>Proceratium</i>	4	0.04 (8)				
	5	0.04 (3)				
	6		0.02 (1)	0.02 (1)	0.06 (3)	
PONERINI						
<i>Anochetus</i>	<i>grandidieri</i>	0.08 (12)	0.02 (1)			
<i>Hypoponera</i>	1		0.14 (18)	0.14 (37)	0.08 (10)	
	6			0.08 (24)		
	9	0.02 (7)				
	11		0.04 (4)	0.06 (3)	0.92 (385)	
	19				0.06 (3)	
	20					0.76 (275)
	21		0.06 (6)	0.14 (15)	0.24 (23)	

TABLE 4-3. *Continued.*

Genus	Species	875 m	1200 m	1280 m	1565 m	1985 m
	22				0.46 (163)	
	23		0.22 (13)		0.04 (2)	
	24				0.06 (4)	
	25		0.90 (397)	0.24 (25)		
	26		0.66 (175)	0.30 (89)		
	28		0.72 (257)	0.06 (17)		
	29		0.04 (4)			
	30		0.06 (8)			
	31	0.04 (4)				
	32	0.52 (159)				
	34	0.22 (15)				
	35	0.04 (2)				
	36	0.50 (149)				
	37	0.04 (8)				
	38	0.78 (289)				
	39	0.18 (24)				
	40	0.02 (1)				
	41	0.08 (115)				
	42	0.02 (7)				
	47	0.02 (1)				
	sakalava	0.10 (11)	0.02 (2)	0.04 (7)		
<i>Leptogenys</i>	5	0.02 (7)				
	9	0.02 (1)				
	11				0.02 (1)	
	14			0.02 (1)		
<i>Odontomachus</i>	coquereli	0.04 (2)				
<i>Pachycondyla</i>	1	0.02 (3)	0.02 (1)			
	3		0.04 (2)			
	cambouei	0.52 (63)	0.10 (7)	0.14 (7)		

* The number of individual workers collected is given in parentheses. Species listed in boldface type were also collected on the Masoala Peninsula (Table 4-4).

and 875 m sites is probably due to differences in the faunal composition between the RS d'Anjanaharibe-Sud and the Masoala Peninsula localities. Therefore, fewer unique species would have been expected from the 825 and 875 m sites if a higher or lower elevation site could have been sampled from the same locality.

Why does species richness increase above 25 m before declining to nine species at 1985 m? Results on the number of shared species between elevations and on species turnover, which suggests a lowland and montane ant fauna, may help explain this pattern. Adjacent elevations share taxa because they may contain similar habitats and because the width of the elevational zones along the gradient is narrow. The proximity of elevational zones encourages the establishment of marginal populations from adjacent elevations (Pulliam, 1988; Stevens, 1989; Rahbek, 1997). Therefore, adjacent elevation sites share species because they are close in space.

Species richness may be highest at midelevations because they are adjacent to the source pool

of the distinct montane ant fauna as well as those from lower elevations. A mixing of the lowland and montane ant assemblages results in the peak in species richness. The midelevation sites share the highest number of species with other sites when compared to the lowest and highest elevations (Table 4-9). The number of species shared with the 25 m site decreases rapidly with elevation. The low-elevation sites are bounded and can only receive species spillover from above, mostly from the adjacent midelevations, with which they already share a high proportion of species.

The effects of abundance on observed species richness could explain differences in observed species richness among elevations (Chazdon et al., in press). Species richness at a site may be a function of abundance: the greater the abundance at an elevation, the higher the species richness. In this study, the relationship between abundance, measured as the total number of stations at which each species was collected, and elevation mirrored that of species richness, but abundance peaked at a lower elevation (Fig. 4-2). There is

TABLE 4-4. Abundance, measured as frequency of occurrence (proportion of stations out of 50 paired pitfall and leaf litter samples at which each species was recorded) for each elevation on the Masoala Peninsula.*

Genus	Species	25 m	425 m	825 m
CERAPACHYINAE				
<i>Cerapachys</i>	1			0.08 (19)
	5			0.60 (17)
	7		0.02 (1)	0.12 (18)
	13			0.02 (1)
	14			0.06 (23)
	16			0.02 (15)
	22	0.04 (2)	0.08 (16)	0.06 (20)
DOLICHODERINAE				
<i>Technomyrmex</i>	3		0.08 (361)	0.04 (3)
FORMICINAE				
CAMPONOTINI				
<i>Camponotus</i>	2			0.02 (1)
	5		0.02 (7)	0.04 (5)
	12			0.02 (10)
	15			0.02 (2)
	16	0.02 (2)	0.14 (17)	0.04 (3)
	24		0.08 (19)	0.02 (1)
	28		0.02 (1)	
	30		0.04 (4)	0.08 (11)
	35	0.06 (3)	0.04 (2)	0.02 (1)
	<i>putatus</i>		0.02 (2)	
LASIINI				
<i>Paratrechina</i>	1	0.76 (617)		
	5	0.40 (276)	0.36 (686)	0.90 (2,950)
	6	0.82 (721)	0.68 (668)	0.02 (2)
	8		0.72 (936)	0.78 (876)
	9		0.04 (51)	
	10	0.12 (10)		
PLAGIOLEPIDINI				
<i>Plagiolepis</i>	3	0.02 (1)	0.14 (59)	0.34 (24)
MYRMICINAE				
CREMATOGASTRINI				
<i>Crematogaster</i>	3	0.04 (3)	0.12 (15)	0.06 (3)
	8	0.24 (40)	0.04 (2)	
	9	0.10 (7)	0.08 (27)	
	12			0.02 (1)
	<i>schenki</i>			0.04 (2)
DACETONINI				
<i>Kyidris</i>	1		0.46 (927)	0.08 (22)
	6	0.02 (2)	0.02 (1)	0.02 (1)
	7	0.02 (1)	0.20 (43)	
<i>Strumigenys</i>	1	0.26 (132)	0.62 (564)	0.60 (224)
	13	0.44 (91)	0.04 (9)	0.02 (1)
	14	0.28 (37)	0.42 (159)	0.04 (5)
	19		0.04 (2)	0.02 (1)
	22	0.36 (79)	0.48 (88)	0.12 (8)
	23			0.12 (6)
	24	0.50 (104)	0.84 (370)	
	25	0.24 (21)	0.02 (1)	0.20 (21)
	26	0.20 (31)	0.32 (56)	0.42 (62)
	27	0.06 (10)	0.38 (89)	
	28	0.04 (10)	0.12 (9)	0.22 (19)
29		0.02 (2)	0.90 (246)	

TABLE 4-4. *Continued.*

Genus	Species	25 m	425 m	825 m
	30			0.14 (20)
	37		0.04 (2)	
	51			0.04 (2)
	52			0.06 (5)
	53	0.16 (30)	0.24 (54)	
	55			0.08 (5)
PHEIDOLINI				
<i>Aphaenogaster</i>	<i>gonacantha</i>		0.38 (33)	
<i>Pheidole</i>	13			0.06 (6)
	20	0.06 (8)	0.68 (866)	
	23	0.02 (2)		
	41			0.06 (67)
	43	0.50 (438)	0.38 (92)	
	44	0.52 (789)	0.58 (847)	0.28 (156)
	49			0.04 (204)
	50	0.12 (66)	0.28 (311)	0.36 (104)
	52			0.02 (7)
	53	0.28 (228)	0.02 (2)	0.18 (191)
	54			0.02 (16)
	58		0.10 (145)	0.52 (571)
	62			0.48 (275)
	63			0.06 (7)
	64			0.20 (96)
	65			0.06 (87)
	66			0.02 (3)
	67			0.04 (34)
	68	0.78 (8,083)	0.96 (10,045)	
	69	0.40 (134)	0.48 (355)	
	70	0.20 (140)	0.22 (246)	
	71	0.50 (951)	0.04 (23)	
	72		0.02 (25)	
	73	0.34 (73)	0.08 (14)	
	74	0.02 (1)		
	<i>oswaldi</i>	0.20 (146)	0.42 (636)	
	<i>spinosa</i>	0.48 (302)	0.46 (180)	
	<i>veteratrix</i>			0.94 (779)
PHEIDOLOGETONINI				
<i>Oligomyrmex</i>	3	0.22 (39)		0.52 (210)
	6	0.12 (30)	0.06 (60)	0.42 (577)
SOLENOPSISINI				
<i>Monomorium</i>	2			0.14 (11)
	5		0.02 (47)	0.02 (1)
	7		0.48 (220)	0.68 (427)
	14	0.42 (81)	0.58 (259)	
	23		0.14 (25)	0.50 (301)
	24			0.22 (81)
	26	0.02 (1)	0.20 (48)	
	28			0.12 (33)
	33			0.18 (23)
	34			0.66 (1,707)
	36	0.08 (10)	0.46 (212)	0.02 (4)
	38			0.02 (2)
	39	0.32 (371)	0.04 (17)	0.64 (1,012)
	41		0.14 (62)	
	42	0.02 (2)		0.06 (25)

TABLE 4-4. *Continued.*

Genus	Species	25 m	425 m	825 m
TETRAMORIINI				
<i>Tetramorium</i>	6		0.02 (1)	0.14 (21)
	7	0.02 (2)		0.02 (5)
	16	0.12 (16)	0.32 (98)	
	21	0.02 (1)	0.12 (10)	
	23	0.52 (110)	0.24 (35)	
	24			0.24 (43)
	25		0.02 (1)	0.10 (6)
	26		0.08 (5)	
	29			0.02 (2)
	34	0.36 (64)	0.12 (12)	
	35	0.04 (3)		
	36		0.40 (261)	
	37		0.18 (85)	0.42 (149)
	39			0.08 (10)
	40	0.40 (181)	0.34 (49)	0.02 (2)
	41	0.56 (104)	0.52 (87)	
	42		0.04 (2)	
	43	0.06 (25)	0.02 (2)	
	<i>andrei</i>	0.64 (285)	0.08 (7)	0.04 (3)
	<i>dysalium</i>	0.28 (45)	0.04 (5)	0.02 (1)
<i>electrum</i>			0.04 (2)	
<i>marginatum</i>		0.74 (366)	0.02 (2)	
<i>naganum</i>	0.18 (21)	0.02 (1)	0.28 (26)	
<i>tosii</i>	0.10 (5)	0.30 (56)		
INCERTAE SEDIS				
Undescribed genus	2			0.80 (221)
	3	0.54 (120)	0.32 (83)	
PONERINAE				
AMBLYOPONINI				
<i>Amblyopone</i>	1		0.02 (1)	
	4			0.04 (3)
<i>Mystrium</i>	3			0.06 (3)
	4	0.50 (104)	0.20 (18)	
	5		0.02 (2)	
<i>Prionopelta</i>	1	0.16 (44)	0.10 (82)	0.14 (33)
	4			0.76 (228)
	5	0.08 (4)	0.24 (25)	
ECTATOMMINI				
<i>Discothyrea</i>	3			0.12 (22)
	5		0.02 (1)	0.08 (27)
	6	0.02 (1)		
	7		0.02 (1)	
<i>Proceratium</i>	2	0.10 (5)	0.02 (1)	
	<i>diplopyx</i>			0.06 (3)
PONERINI				
<i>Anochetus</i>	<i>grandidieri</i>	0.34 (71)	0.24 (97)	0.02 (14)
<i>Hypoponera</i>	22			0.04 (8)
	26		0.02 (1)	0.64 (181)
	29			0.02 (1)
	32	0.38 (60)	0.46 (260)	
	33	0.68 (216)	0.06 (6)	
	36	0.34 (76)	0.68 (310)	
	38			0.32 (87)
	39			0.88 (986)
	43	0.12 (21)	0.06 (25)	

TABLE 4-4. *Continued.*

Genus	Species	25 m	425 m	825 m
	44	0.20 (103)	0.38 (180)	
	46	0.06 (12)	0.06 (3)	0.18 (38)
	47		0.18 (79)	0.46 (185)
	48			0.02 (2)
	49			0.04 (5)
	50			0.04 (2)
	51		0.12 (18)	
	52	0.02 (1)		
	sakalava	0.06 (6)	0.08 (10)	0.02 (3)
<i>Leptogenys</i>	4		0.02 (2)	
	5			0.02 (9)
	6			0.04 (3)
	7			0.02 (1)
	11			0.02 (1)
<i>Odontomachus</i>	coquereli		0.02 (1)	0.02 (1)
<i>Pachycondyla</i>	1			0.14 (20)
	2	0.20 (15)	0.14 (10)	
	cambouei	0.08 (5)	0.12 (7)	0.20 (15)
	perroti	0.04 (4)		
<i>Ponera</i>	1	0.06 (9)	0.34 (70)	

* The number of individual workers collected is given in parentheses. Species listed in boldface type were also collected in the RS d'Anjanaharibe-Sud (Table 4-3).

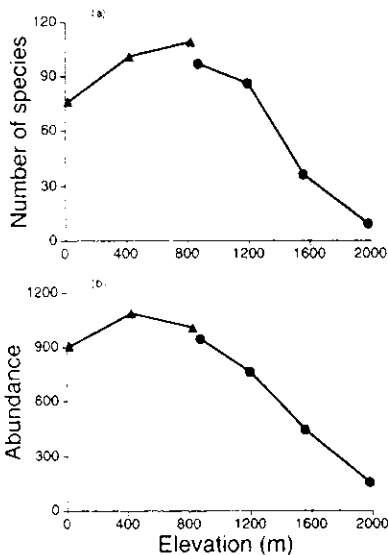

FIG. 4-2. Number of ant species (a) and total abundance (b) as a function of elevation. Abundance is measured as the total number of stations at which each species was collected (see text for details). Data are from pitfall and mini-Winkler samples from the Masoala Peninsula (\blacktriangle , 25–825 m) and the RS d'Anjanaharibe-Sud (\bullet , 875–1985 m).

also a significant relationship between observed species richness and abundance, measured as the total number of stations at which each species was collected (Fig. 4-5; $r^2 = .94$, $p < 0.0005$). The relationship between species richness and elevation, however, cannot be attributed to differences in abundance. Observed species accumulation curves based on abundance, measured as the total number of stations at which each species was collected (not number of stations sampled), for each elevation are not identical (Fig. 4-6). Species-rich sites have a higher rate of discovery of new species than species-poor sites. Thus, comparisons of observed species richness across sites were not confounded by the potential sampling-induced bias of differences in abundance.

Efficacy of Inventory Methods

For all elevations sampled, species accumulation curves appear to be leveling off toward an asymptote and thus reflect the actual number of species present in the area sampled along the 250 m transect at each elevation site. Additional collecting methods, or a survey in a different area or season at the same elevation, would most likely result in the collection of additional species. The ICE- and jackknife-estimated species richnesses are almost identical for each elevation when all

TABLE 4-5. Total number of species and relative importance (%) of each subfamily for pitfall and leaf litter collections on the Masoala Peninsula and in the RS d'Anjanaharibe-Sud (general collections are excluded).

Altitude (m)	Subfamily*					
	Cerap	Dolichod	Form	Pon	Myrm	P/M [†]
Masoala						
25	1 (1%)	0	7 (9%)	18 (24%)	50 (66%)	0.36
425	2 (2%)	1 (1%)	12 (12%)	24 (24%)	62 (62%)	0.39
825	7 (6%)	1 (1%)	12 (11%)	26 (23%)	63 (56%)	0.41
All elevations	7 (4%)	1 (1%)	17 (10%)	44 (26%)	98 (59%)	0.45
RS d'Anjanaharibe-Sud						
875	6 (6%)	0	9 (9%)	31 (32%)	51 (53%)	0.61
1200	5 (6%)	1 (1%)	12 (14%)	19 (22%)	49 (57%)	0.39
1280	3 (6%)	0	4 (8%)	14 (26%)	32 (60%)	0.44
1565	2 (4%)	0	8 (16%)	10 (20%)	30 (60%)	0.33
1985	0	0	2 (22%)	1 (11%)	6 (66%)	0.17
All elevations	12 (7%)	1 (1%)	18 (10%)	50 (28%)	99 (55%)	0.51

* Cerap = Cerapachyinae; Dolichod = Dolichoderinae; Form = Formicinae; Pon = Ponerinae; and Myrm = Myrmicinae.

[†] P/M = taxonomic ratio of species in the Ponerinae and Myrmicinae.

stations are pooled (Figs. 4-3, 4-4). In some cases (e.g., Fig. 4-3b, d), the ICE method was less sensitive to sample size than the jackknife method. The precision of these estimators is difficult to determine because a site would need to be exhaustively surveyed to produce a complete species list. Nevertheless, these results show that the inventory techniques used in this study provide sufficient sampling for statistical estimation, comparison of species richness, and comparison of faunal similarity and species turnover.

An alternative approach to evaluating the ques-

tion of efficacy is to ask what minimum number of collections is necessary to provide the same relative ranking of species richness among elevations, as shown in Figure 4-2. Do pitfall samples alone show the same midelevation peak? No; within the Masoala Peninsula locality, the 825 m site had the lowest number of species recorded from pitfalls. Species accumulation curves for pitfall samples are still rising rapidly after 50 samples, which suggests that pitfall samples in this study do not provide sufficient sampling for comparison among elevations. Alternatively, it is pos-

TABLE 4-6. Number of species collected and first-order jackknife and ICE estimates of total species richness (with 95% confidence intervals) based on pitfall and leaf litter transects on the Masoala Peninsula and in the RS d'Anjanaharibe-Sud.*

Altitude (m)	Observed	ICE	95% CI [†]	Jackknife	95% CI [†]
Masoala					
25	76	84.8	0.26	87.8	0.77
425	101	120.3	0.38	122.6	0.93
825	109	141.7	0.47	139.4	1.04
All elevations	167	187.7	0.35	193.8	1.01
RS d'Anjanaharibe-Sud					
875	97	126.7	0.68	122.5	1.12
1200	86	97.4	0.27	101.7	0.71
1280	52	63.4	0.29	65.5	0.57
1565	50	66.3	0.34	63.7	0.62
1985	9	11.3	0.16	11.0	0.27
All elevations	179	209.9	0.03	214.3	1.23

* Statistics are given for each altitude and for all elevations combined. The observed and estimated species richness values for 1280 m are based on 26 leaf litter and the first 26 pitfall trap samples.

[†] CI = confidence interval.

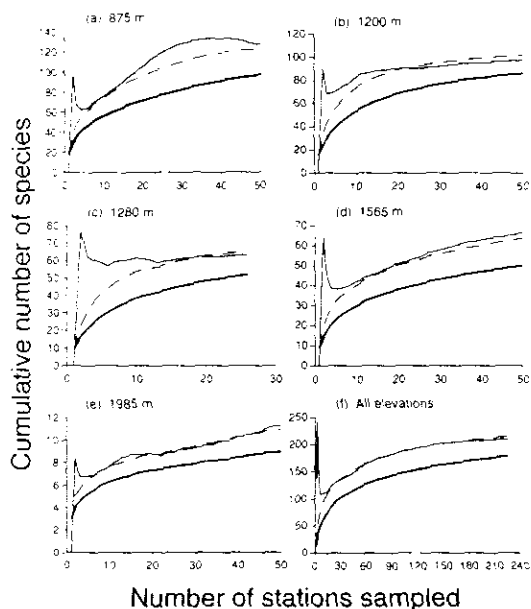

FIG. 4-3. Assessment of leaf litter ant sampling technique for each elevation (a-e) and for all elevations combined (f) in the RS d'Anjanaharibe-Sud. The lower species accumulation curve (thick line) in each chart plots the observed number of species as a function of the number of stations sampled. The upper curves display the nonparametric first-order jackknife (dashed line) and the ICE (thin line) estimated total species richness based on successively larger number of samples from the data set (Heltshé & Forrester, 1983; Lee & Chao, 1994). Curves are plotted from the means of 100 randomizations of sample accumulation order.

TABLE 4-8. Beta-1 (above the diagonal) and beta-2 (below the diagonal) diversity values of each pair of altitude sites.*

RS d'Anjanaharibe-Sud [†]				
Elevation	875 m	1200 m	1565 m	1985 m
875 m	—	0.563	0.838	0.981
1200 m	0.474	—	0.618	0.979
1565 m	0.392	0.280	—	0.967
1985 m	0.082	0.093	0.080	—
Masoala Peninsula [‡]				
Elevation	25 m	425 m	825 m	
25 m	—	0.266	0.643	
425 m	0.110	—	0.514	
825 m	0.394	0.459	—	
Between the RS d'Anjanaharibe-Sud (875 m) and the Masoala Peninsula (825 m)				
	875 and 825 m	All elevations		
β-1	0.553	0.562		
β-2	0.486	0.506		

* Higher values represent greater species turnover. Values in boldface type represent comparisons of altitudinally adjacent transects.

[†] Overall beta-1 diversity was 2.050; beta-2 diversity was 0.856.

[‡] Overall beta-1 diversity was 0.752; beta-2 diversity as 0.532.

TABLE 4-7. Two measurements of faunal similarity between elevational zones and regions sampled.*

RS d'Anjanaharibe-Sud				
Elevation	875 m	1200 m	1565 m	1985 m
875 m	—	0.280	0.089	0.010
1200 m	0.272	—	0.236	0.011
1565 m	0.093	0.198	—	0.093
1985 m	0.000	0.002	0.228	—
Masoala Peninsula				
Elevation	25 m	425 m	825 m	
25 m	—	0.580	0.217	
425 m	0.659	—	0.321	
825 m	0.170	0.270	—	
Between the RS d'Anjanaharibe-Sud (875 m) and the Masoala Peninsula (825 m)				
	875 and 825 m	All elevations		
Jaccard Index	0.288	0.280		
Morisita Index	0.322	—		

* Above the diagonal is the Jaccard Index of similarity (presence and absence data), and below the diagonal, the simplified Morisita Index of similarity (abundance data; Horn, 1966). Higher values represent greater similarity. Values in boldface type represent comparisons of altitudinally adjacent transects.

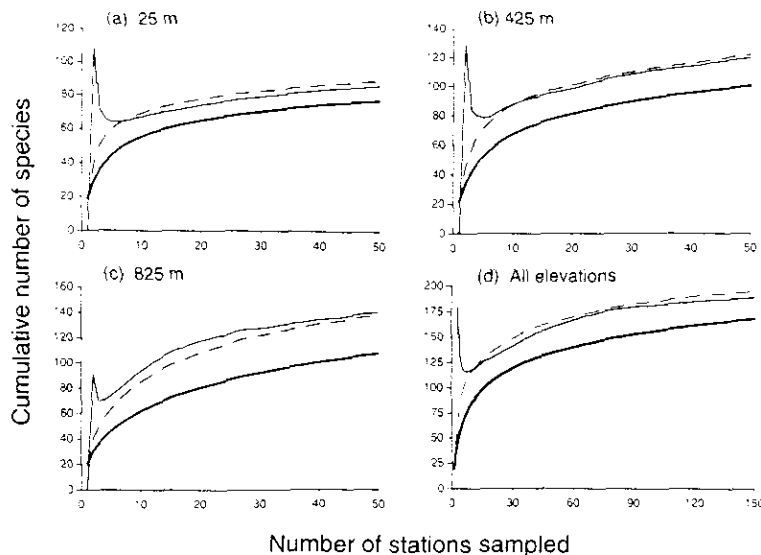

FIG. 4-4. Assessment of leaf litter ant sampling technique for each elevation (a-c) and for all elevations combined (d) on the western Masoala Peninsula. The lower species accumulation curve (thick line) in each chart plots the observed number of species as a function of the number of stations sampled. The upper curves display the nonparametric first-order jackknife (dashed line) and ICE (thin line) estimated total species richness based on successively larger number of samples from the data set (Heitshe & Forrester, 1983; Lee & Chao, 1994). Curves are plotted from the means of 100 randomizations of sample accumulation order.

sible that pitfalls sample a different subset of the ant fauna that does not show a midelevation peak. For mini-Winkler samples, the same relative ranking in observed species richness was reached and maintained after 25 samples. A lower number of leaf litter samples will produce a more incomplete species list necessary for species turnover and faunal similarity studies, but fewer samples may be appropriate for addressing questions on the relative ranking of species richness.

Comparisons with Other Faunas

The ant fauna of Madagascar is incompletely known, with two-thirds of the 1,000 estimated species on the island thought to be undescribed (Fisher, 1996b, 1997). No previous records exist for ants collected in the RS d'Anjanaharibe-Sud. Mocquery collected in the late 19th century near the Baie d'Antongil, approximately 90 km south-southeast of the RS d'Anjanaharibe-Sud (Emery,

TABLE 4-9. Number of species shared between elevations from the Masoala Peninsula (25-825 m) and the RS d'Anjanaharibe-Sud (875-1985 m).*

Elevation	25	425	825	875	1200	1565	1985
25	6 (8)						
425	65	13 (13)					
825	33	51	39 (36)				
875	31	40	46	37 (38)			
1200	25	31	42	40	18 (21)		
1565	10	10	11	12	26	16 (32)	
1985	1	1	1	1	1	5	4 (44)

* The 1280 m site is excluded. The number and percentage (in parentheses) of species unique to an elevation are presented along the diagonal. The number of species unique to 875 m was calculated in the absence of the 825 m data. Likewise, 875 m data were not used in calculating species unique to the 825 m site.

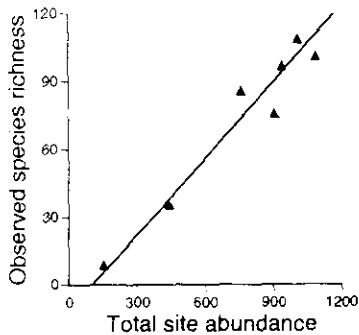

FIG. 4-5. Number of total species at each elevation from the RS d'Anjanaharibe-Sud and the western Masoala Peninsula plotted as a function of total abundance, which was measured as the total number of stations at which each species was collected ($r^2 = 0.94$, $P < 0.005$).

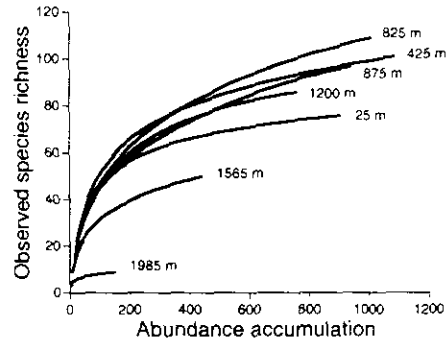

FIG. 4-6. Observed species richness accumulation curves for each elevation plotted as a function of abundance, which was measured as the total number of stations at which each species was collected. Curves are plotted from the means of 100 randomizations of sample accumulation order.

1899), and provided important collections for the region (Wheeler, 1922). Subsequent collections in the Baie d'Antongil region have been made by Ward and Alpert.

For the island of Madagascar, 90% of the valid specific and subspecific ant taxa are endemic (Fisher, 1996b, 1997). In the RS d'Anjanaharibe-Sud, 100% of the ants collected are thought to be endemic to Madagascar, except for *Serrastruma ludovici*, which is widespread in Africa and is also known from Mauritius (Bolton, 1983). On the Masoala Peninsula, the lowest elevations contained two tramp species. These tramp species were collected in open areas along sandy beaches (*Tetramorium bicarinatum*) and disturbed forest areas (*Technomyrmex albipes*) and were not encountered in the undisturbed forest transects. We do not know how susceptible the forest ant assemblages of Madagascar are to invasion by tramp species, especially *Technomyrmex albipes*. In the RS de Nosy Mangabe, field observations by P. S. Ward (pers. comm.) suggest that ant diversity is depressed in areas occupied by *Technomyrmex albipes*. Monitoring efforts should be directed at measuring the advance of this species from disturbed habitats to relatively undisturbed habitats. As fragmentation of the remaining forest habitats increases in Madagascar, their susceptibility to invasion will probably increase.

The high similarity of the ant fauna of the 875 m site in the RS d'Anjanaharibe-Sud and 825 m site on the Masoala Peninsula (Table 4-7) suggests a shared history. The two sites are located approximately 110 km apart and are connected by a

band of midelevation forest. Even given this similarity, many differences in species assemblages still exist between the two sites (Tables 4-1, 4-3). The endemic genus *Eutetramorium* was abundant in general collections at 875 m in the RS d'Anjanaharibe-Sud (*E. mocquerysi*) but was not collected on the western side of the Masoala Peninsula, although this species is known from the RNI de Marojejy and on the eastern side of Masoala Peninsula (Alpert & Rabeson, in press). An undescribed endemic myrmicine genus was abundant at both localities, but different species were found at each.

The relative prevalences of species from the subfamilies Ponerinae and Myrmicinae are similar in the RS d'Anjanaharibe-Sud (28% and 55%, respectively) and on the Masoala Peninsula (26% and 59%, respectively) (Table 4-5). The Ponerinae/Myrmicinae ratio (0.51 and 0.45, respectively) is greater than that found for the RNI d'Andringitra (0.35; Fisher, 1996a) and other tropical sites in sub-Saharan Africa, Central America, and Australia (Table 8-6 in Fisher, 1996a). Previous results suggested that a 1:3 ratio of Ponerinae to Myrmicinae could be used to interpolate the species richness of one subfamily from the other (Fisher, 1996a). Because of the differences in ratios among localities and elevations, the current study suggests that the 1:3 taxonomic ratio is not universal. The application of taxonomic ratios to estimating ant species richness in Madagascar may not be appropriate and will require, at a minimum, region- and elevation-specific calibrations.

Acknowledgments

I am very grateful to S. M. Goodman for organizing the project in the RS d'Anjanaharibe-Sud, C. Kremen for assistance in logistics on the Masoala Peninsula, the villagers of Ambanizana for their hospitality and assistance, P. S. Ward for encouragement and assistance in ant taxonomy, R. K. Colwell for help in data management and analysis, and J. Chranowski, J. Defoe, P. Rabeson, and D. Rosen for data entry and collection curation. In addition, S. Cover, C. Kremen, S. M. Goodman, and P. S. Ward made valuable comments on the manuscript. This project was funded by the World Wide Fund for Nature, Madagascar, the National Geographic Society (grant 5152-93), and the National Science Foundation (grant INT 9319515).

Literature Cited

- ALPERT, G. D., AND P. RABESON. In press. *Eutetrarium*, a rare ant genus endemic to Madagascar (Hymenoptera: Formicidae). *Psyche*.
- BESUCHET, C., D. H. BURCKHARDT, AND I. LOBL. 1987. The "Winkler/Moczarski" ector for fungus and litter Coleoptera. *The Coleopterists Bulletin*, **41**: 393-394.
- BOLTON, B. 1983. The Afrotropical dacetine ants (Formicidae). *Bulletin of the British Museum (Natural History)*, Entomology Series, **46**: 267-416.
- BROWN, W. L., JR. 1973. A comparison of the Hylean and Congo-West African rain forest ant faunas, pp. 161-185. In Meggers, B. J., E. S. Ayensu, and W. D. Duckworth, eds., *Tropical Forest Ecosystems in Africa and South America: A Comparative Review*. Smithsonian Institution Press, Washington, D.C.
- CHAZDON, R. L., R. K. COLWELL, J. S. DENSLOW, AND M. R. GUARIGUATA. In press. Statistical methods for estimating species richness of woody regeneration in primary and secondary rain forests of NE Costa Rica. In Dallmeier, F., ed., *Proceedings of the SIMAB International Symposium on Measuring and Monitoring Forest Biological Diversity: The International Network of Biodiversity Plots*. Smithsonian Institution Press, Washington, D.C.
- COLWELL, R. K., AND J. A. CODDINGTON. 1994. Estimating terrestrial biodiversity through extrapolation. *Philosophical Transactions of the Royal Society of London, Series B*, **345**: 101-118.
- EMERY, C. 1899. Formiche di Madagascar raccolte dal Sig. A. Mocquerys nei pressi della Baia di Antongil (1897-1898). *Bullettino della Società Entomologica Italiana*, **31**: 263-290.
- FISHER, B. L. 1996a. Ant diversity patterns along an elevational gradient in the Réserve Naturelle Intégrale d'Andringitra, Madagascar, pp. 93-108. In Goodman, S. M., ed., *A floral and faunal inventory of the eastern slopes of the Réserve Naturelle Intégrale d'Andringitra, Madagascar: With reference to elevational variation*. *Fieldiana: Zoology, n.s.*, **85**: 1-319.
- . 1996b. Origins and affinities of the ant fauna of Madagascar, pp. 457-465. In Lourenco, W. L., ed., *Biogéographie de Madagascar*. Editions ORSTOM, Paris.
- . 1997. Biogeography and ecology of the ant fauna of Madagascar (Hymenoptera: Formicidae). *Journal of Natural History*, **31**: 269-302.
- FISHER, B. L., AND S. RAZAFIMANDIMBY. 1997. Les Fourmis (Hymenoptera: Formicidae), pp. 105-111. In Goodman, S. M., and O. Langrand, eds., *Inventaire biologique forêt de Vohibasia et d'Isoky-Vohimana. Série Sciences biologiques. N° Spéciale. World Wide Fundfer Nature, Centre d'Information et de Documentation Scientifique et Technique*. Antananarivo.
- GASTON, J. K., T. R. NEW, AND M. J. SAMWAYS, EDs. 1993. *Perspectives on insect conservation*. Intercept Ltd., Andover, UK. 250 pp.
- HARRISON, S., S. J. ROSS, AND J. H. LAWTON. 1992. Beta diversity on geographic gradients in Britain. *Journal of Animal Ecology*, **61**: 151-158.
- HELTSHE, J. E., AND N. E. FORRESTER. 1983. Estimating species richness using the jackknife procedure. *Biometrics*, **39**: 1-11.
- HORN, H. S. 1966. Measurement of 'overlap' in comparative ecological studies. *American Naturalist*, **100**: 419-424.
- LEE, S.-M., AND A. CHAO. 1994. Estimating population size via sample coverage for closed capture-recapture models. *Biometrics*, **50**: 88-97.
- MAGURRAN, A. E. 1988. *Ecological Diversity and Its Measurement*. Princeton University Press, Princeton, N.J., 179 pp.
- OLSON, D. M. 1994. The distribution of leaf litter invertebrates along a Neotropical altitudinal gradient. *Journal of Tropical Ecology*, **10**: 129-150.
- PALMER, M. W. 1995. How should one count species? *Natural Areas Journal*, **15**: 124-135.
- PULLIAM, H. R. 1988. Source, sinks, and population regulation. *The American Naturalist*, **132**: 652-661.
- RAHBEK, C. 1995. The elevational gradient of species richness: A uniform pattern? *Ecography*, **18**: 200-205.
- . 1997. The relationship between area, elevation, and regional species richness in Neotropical birds. *The American Naturalist*, **149**: 875-902.
- ROSENZWEIG, M. L., AND Z. ABRAMSKY. 1993. How are diversity and productivity related? pp. 52-65. In Ricklefs, R., and D. Schluter, eds., *Species Diversity in Ecological Communities: Historical and Geographical Perspectives*. University of Chicago Press, Chicago.
- STEVENS, G. C. 1989. The latitudinal gradient in geographical range: How so many species coexist in the tropics. *The American Naturalist*, **133**: 240-256.
- . 1992. The elevational gradient in altitudinal range: An extension of Rapoport's latitudinal rule to altitude. *The American Naturalist*, **140**: 893-911.
- WHEELER, W. M. 1922. Ants of the American Museum Congo expedition: A contribution to the myrmecology of Africa. IX. A synonymic list of the ants of the Malagasy region. *Bulletin of the American Museum of Natural History*, **45**: 1005-1055.
- WHITTAKER, R. M. 1960. Vegetation of the Siskiyou Mountains, Oregon and California. *Ecological Monographs*, **30**: 279-338.
- WOLDA, H. 1981. Similarity indices, sample size and diversity. *Oecologia*, **50**: 296-302.